

Design, prototyping and control of a flexible cystoscope for biomedical applications

Canberk Sozer¹, Morteza Ghorbani^{2,3}, Gokhan Alcan^{2,4}, Huseyin Uvet¹, Mustafa UneI^{2,4}, Ali Kosar^{2,3}

¹Mechatronics Engineering Department, Yildiz Technical University, Istanbul, Turkey

²Faculty of Engineering and Natural Science, Sabanci University, Istanbul, Turkey

³Sabanci University Nanotechnology Research and Application Center, Istanbul, Turkey

⁴Integrated Manufacturing Technologies Research and Application Center, Sabanci University, Istanbul, Turkey

Abstract. Kidney stone and prostate hyperplasia are very common urogenital diseases all over the world. To treat these diseases, one of the ESWL (Extracorporeal Shock Wave Lithotripsy), PCNL (Percutaneous Nephrolithotomy), cystoscopes or open surgery techniques can be used. Cystoscopes named devices are used for in-vivo intervention. A flexible or rigid cystoscope device is inserted into human body and operates on interested area. In this study, a flexible cystoscope prototype has been developed. The prototype is able to bend up to $\pm 40^\circ$ in X and Y axes, has a hydrodynamic cavitation probe for rounding sharp edges of kidney stone or resection of the filled prostate with hydrodynamic cavitation method and contains a waterproof medical camera to give visual feedback to the operator. The operator steers the flexible end-effector via joystick toward target region. This paper presents design, manufacturing, control and experimental setup of the tendon driven flexible cystoscope prototype. The prototype is 10 mm in outer diameter, 70 mm in flexible part only and 120 mm in total length with flexible part and rigid tube. The experimental results show that the prototype bending mechanism, control system, manufactured prototype parts and experimental setup function properly. A small piece of real kidney stone was broken in targeted area.

1 Introduction

Nowadays, robotics is widely used in production industry, defense industry and medical field. Many surgeries are performed by robots or robotic-assistant methods and open surgery is seldom in use. Devices used for surveillance and intervention in medical field are called as endoscope. If an endoscope is specialized for urogenital diseases it is called as cystoscope. The cystoscopes can be grouped as rigid and flexible cystoscopes. The rigid cystoscopes consist of just a rigid tube and the flexible cystoscopes include a flexible section in addition to the rigid tube.

The first primitive endoscopic device was created by Philipp Bozzini in 1806 [1], and the modern rigid cystoscope concept was presented by Maximilian Carl-Friedrich Nitze in 1879 [2]. Those devices have been evolving and as a result of continuous improvements, flexible cystoscope devices have been created [3]. The flexible section has significant advantages over the rigid cystoscope such as better postoperative hematuria, less pain and less need of medication, increasing patient and doctor comfort and compatibility [4-6].

Rigid cystoscopes include just a rigid tube and the operator has to reposition the whole device to reach the target. Flexible cystoscopes, on the other hand, have a flexible section in addition to the rigid tube. So, the operator just steers the bendable end-effector using joystick to reach the target.

The design and control of the flexible endoscopic robot arms have been widely studied in medical robotics field. Kato et al. (2015) developed forward kinematic mapping of a two segmented tendon-driven endoscopic robot arm which bends up to 180° [7]. Lei et al. (2010) presented bending mechanism of a tendon-driven flexible ureteroscope [8]. Seneci et al. (2014) described kinematic model and precise control strategy for a 2 DoF flexible robot arm for transluminal and endoluminal surgery [9]. Maeda et al. (1996) developed an active endoscope with 2 mm outer diameter that was actuated by a SMA coil spring [10]. De Sars et al. (2010) presented design and control of a 2 DoF active endoscope steered by two pairs of antagonist SMA wires [11].

In this study, a tendon wire driven cystoscope which has a flexible section has been developed. The aim of the cystoscope platform is to steer the hydrodynamic cavitation probe [12] to the target using a fully manual joystick. The prototype cystoscope has six channels; one for hydrodynamic cavitation tube, one for waterproof medical camera enclosed by fiber optic illumination system, and four 90° positioned channels for stainless steel tendon wires to transmit the deflection from Stewart platform to the end-effector. The probe is used for rounding the sharp edges of kidney stones and resectioning the prostate organ. The fiber optic illumination system is used for illuminating the dark space inside body and camera is used to provide visual feedback to the operator to show the position of the end-effector and the target. The flexible end-effector can bend up to $\pm 40^\circ$ in X and Y axes, and is controlled by fully manual joystick. The outer diameter of the platform is 10 mm and the length of the total prototype is 120 mm.

The rest of the paper is organized as follows: the prototype of the system is provided in Section 2, proposed control scheme is presented in Section 3, manufactured experimental setup is shown in Section 4 and finally the paper is concluded with some remarks and possible future directions in Section 5.

2 Design and Prototyping of a Flexible Cystoscope

The prototype aims steering the hydrodynamic cavitation probe to erode kidney stone surface and treat prostate diseases. To this end, design criteria have been defined by considering available components of the prototype; hydrodynamic cavitation probe with 1.58 mm outer diameter, a micro ScoutCam™ (Medigus Ltd., Israel) waterproof camera enclosed by an illumination system with 2 mm outer diameter, and four 90° circularly positioned stainless steel tendon wires with 1 mm outer diameter. To address all of the requirements, the prototype includes a 1.7 mm in diameter channel for hydrodynamic cavitation probe, a 2.1 mm in diameter channel for imaging and illuminating system and four 1.25 mm in diameter channels for stainless steel tendons. The whole prototype is 10 mm in outer diameter (Figure 1(a)).

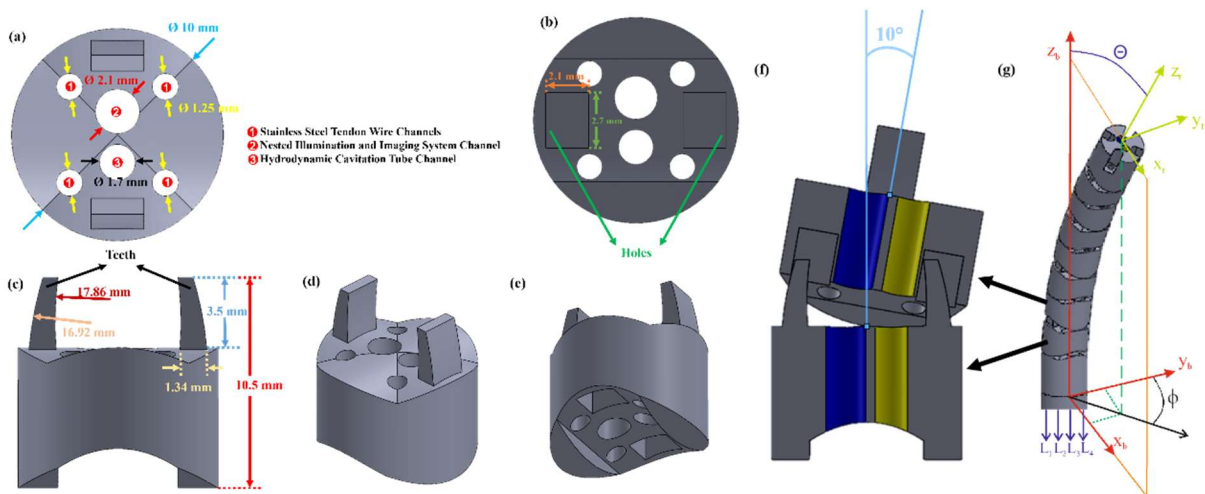

Figure 1. (a) The outer and channel diameters of bendable spacer in X axis; the placement of components, (b) dimensions of the holes, (c) length of the part, (d) and (e) perspective view of the part, (f) bending mechanism of a flexible pair, (g) the relationship between actuation space (L) and joint space (θ, ϕ)

The flexible part consists of 4 different micromanipulator pieces; base part, bendable spacer in X axis, bendable spacer in Y axis and distal end part. The base part has just teeth on the top surface, the X and Y bendable spacers have teeth on the top surface and holes on the bottom surface, the distal end part has just holes on the bottom surface. Thanks to the teeth-holes structure, the flexibility of the bending mechanism has been achieved. The holes are 2.1 mm in length, 2.7 mm in width and 2.72 mm in depth (Figure 1(b)). The teeth are 1.34 mm in length, 2.5 mm in width and 3.5 mm in depth with 16.92 mm in outer and 17.86 mm in inner radius of curvature. This curvy structure provides centering and bending. The base part is 12.5 mm in length with teeth, the spacers are 10.5 mm in length (Figure 1(c)) with teeth and the distal end part is 11 mm in length. When the flexible section is in 0° initial position, teeth get into the holes and the total length of the flexible section becomes 70 mm.

The flexible part of the prototype is able to bend up to $\pm 40^\circ$ in X and Y axes. The bending mechanism consists of 9 parts. These parts create 8 joints and the bending occurs at these points. Each joint can bend $\pm 10^\circ$ in a single axis (Figure 1(f)). This limitation is due to the physical restriction of the teeth-holes structure. Four of the eight joints provide bending in X axis and the remaining four joints provide bending in Y axis. When the parts are aligned in the proper order, the flexible end-effector can bend up to $\pm 40^\circ$ in X and Y axes. In 40° maximum bending angle, radius of curvature of the prototype is 80.3 mm.

To control position of the flexible section, HXP50 6-axis Hexapod (Newport, USA) was used as an actuator. The hexapod gets motion command from the operator via joystick and repositions the moving top plate. The motion of the top plate is transmitted by stainless steel tendon wires to the flexible part.

The relationship between actuation space (L_1, L_2, L_3 and L_4) and joint space (θ and ϕ) parameters is given in the following equations. These formulas [13] are used to determine bending angles in terms of linear displacement of the tendon wires (Figure 1(g)). When tendons are pulled 2.5 mm linearly, the flexible end-effector bends 40° .

$$L_1 = L_0 + 2N_f \left[b \sin\left(\frac{\theta}{2}\right) - h_0 \sin^2\left(\frac{\theta}{4}\right) \right] \quad (1)$$

$$L_2 = L_0 + 2N_f \left[a \sin\left(\frac{\theta}{2}\right) - h_0 \sin^2\left(\frac{\theta}{4}\right) \right] \quad (2)$$

$$L_3 = L_0 - 2N_f \left[b \sin\left(\frac{\theta}{2}\right) + h_0 \sin^2\left(\frac{\theta}{4}\right) \right] \quad (3)$$

$$L_4 = L_0 - 2N_f \left[a \sin\left(\frac{\theta}{2}\right) + h_0 \sin^2\left(\frac{\theta}{4}\right) \right] \quad (4)$$

where $a = \frac{d}{2} \sin(\phi)$, $b = \frac{d}{2} \cos(\phi)$ are distances of the tendons to the bending neutral plane, d is the distance between the tendons in a pair, ϕ is bending direction, L_0 is length of tendons at initial position, N_f is free joint number, θ is total bending angle.

3 Control

The operator gets real time visual feedback from the camera inside the prototype and gives input to the joystick. The joystick commands are processed by MATLAB to produce hexapod commands which are then sent to the hexapod controller to reposition the flexible part through hexapod to approach the specimen (Figure 2).

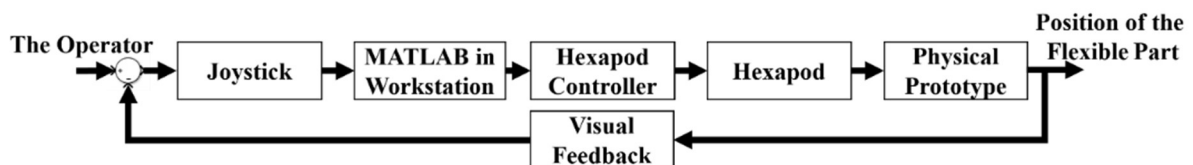

Figure 2. Control system for the prototype

As mentioned before, tendons must be pulled and released 2.5 mm to reach 40° maximum bending angle. When a tendon is pulled, cross tendon wire is released in the same amount. To achieve this, roll and pitch angles of hexapod were used. Both of those motions enable cross tendon's pull-release motion.

A perforated plexiglass plate is attached over the top platform of the hexapod and tendon wires were fixed (see Section 4). All of the selected holes on plexiglass plate are 35.86 mm away from the origin along both vertical and horizontal directions. To pull the tendon wire 2.5 mm, the hexapod must be bent approximately 4° in roll or pitch angles around X and Y axes, respectively.

4 Experimental Setup and Results

The parts of the flexible section have been designed in SolidWorks 3D CAD design software. The first prototype was manufactured with plastic based VisiJet M3 Proplast material by ProJet 3500 HDMax (3D System, USA) 3D printer and after its bending confirmation, the parts were produced with steel based MaragingSteel MS1 material using M 290 (EOS, Germany) DMLS 3D printer.

A plastic based piece was placed into a 10 mm in outer and 8 mm in inner diameter stainless steel tube to separate tendons, imaging and illuminating system and hydrodynamic cavitation tube. The manufactured parts were put at the end of the tube in the proper order and tips of 4 tendon wires were attached to the distal end part of the prototype.

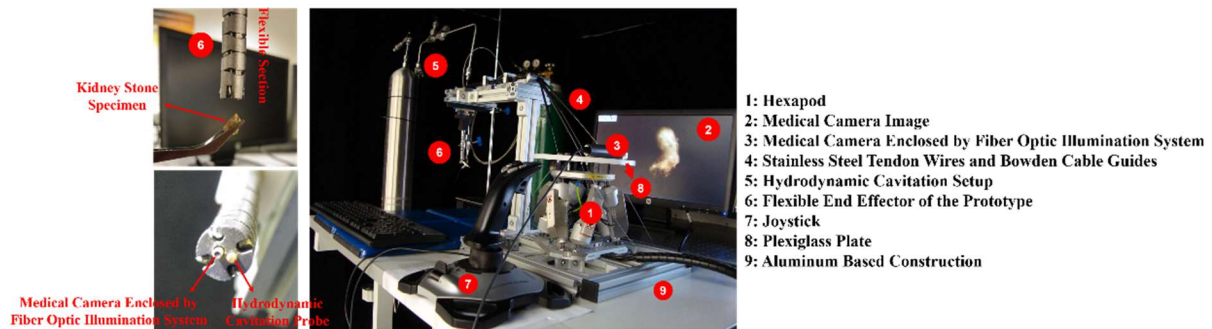

Figure 3. Experimental setup

Aluminum profiles were attached each other to construct the base of the experimental setup. The hexapod, bowden cable holders for guiding tendon wires and a prototype holder were fixed on the setup. The perforated plexiglass plate was placed on the moving top plate of the hexapod to fix tendon wires. The bowden cables were inserted into the bowden cable holders. After the prototype inserted into the prototype holder, other tips of tendons were fixed to the plexiglass plate by passing through prototype holder and bowden cables, respectively (Figure 3).

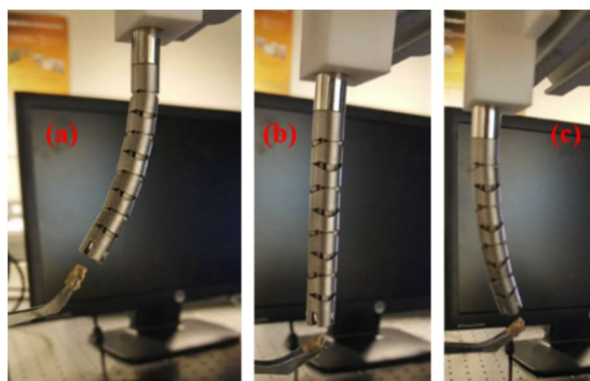

Figure 4. (a) 40° bending angle in +X axis (b) 0° initial position (c) 30° bending angle in -X axis

The prototype system was tested for in-vitro experiments. The real kidney stone was fixed at different points in the workspace of the prototype. The flexible end-effector was locked at different angles from 0° to 40° according to the position of the stone using joystick and cavitation was initiated (Figure 4).

When the flexible end-effector was unlocked, it turned to its initial position. In addition, the flexible part was moved on the stone to reach different points on the stone surface. As a result, the prototype successfully broke the targeted point on the kidney stone using hydrodynamic cavitation.

5 Conclusion and Future Directions

We have now presented mechanical design, prototyping and control of a cystoscope for biomedical applications. The fully manual joystick controlled prototype steers the hydrodynamic cavitation probe toward the specimen (e.g. kidney stone, prostate). To provide bending up to $\pm 40^\circ$ in X and Y axis, a suitable teeth – holes structure has been designed. The relationships between tendon wires linear displacements and bending angles were utilized to determine the bending angles. Joystick commands are processed in MATLAB and hexapod commands are generated. The prototype was used for in-vitro experiments with real kidney stone and a small piece of kidney stone was successfully broken with hydrodynamic cavitation.

As future directions, semi-automatic and fully-automatic vision based control will be implemented in the proposed flexible cystoscope system, which will include real-time processing of the images acquired by the camera placed in the flexible part of the micromanipulator.

Acknowledgment

This project was supported by TUBITAK (The Scientific and Technological Research Council of Turkey) under Grant No 113S092.

References

- [1] Doglietto F, Prevedello D M, Jane Jr J A, Han J, and Laws Jr E R 2005 A brief history of endoscopic transsphenoidal surgery—from Philipp Bozzini to the First World Congress of Endoscopic Skull Base Surgery *Neurosurgical focus* **19(6)** 1-6
- [2] Herr H W 2006 Max Nitze, the cystoscope and urology *The Journal of urology* 1313-16
- [3] Kavoussi L R and Clayman R V 1988 Office flexible cystoscopy *The Urologic clinics of North America* **15(4)** 601-608
- [4] Erdem M R, Topaloğlu K, Yücebaş Ö E, Şengör F, Aslan A R, Tosun Ç, Ramazanoğlu M A and Duvar S 2015 Better Comfort for Both Patient and Doctor: Prospective Randomized Study about Flexible and Rigid Cystoscopy *Journal of Urological Surgery* **2** 65-8
- [5] Flannigan G M, Gelister J S K, Noble J G and Milroy E J G 1988 Rigid versus Flexible Cystoscopy A Controlled Trial of Patient Tolerance *British journal of urology* **62(6)** 537-40
- [6] Denholm S W, Conn I G, Newsam J E and Chisholm G D 1990 Morbidity following cystoscopy: comparison of flexible and rigid techniques *BJU International* **66(2)** 152-4
- [7] Kato T, Okumura I, Song S E, Golby A J, and Hata, N 2015 Tendon-driven continuum robot for endoscopic surgery: preclinical development and validation of a tension propagation model *IEEE/ASME Transactions on Mechatronics* **20(5)** 2252-63
- [8] Lei M C and Du R 2010 *International Conference on Control Automation and Systems (ICCAS)* IEEE Gyeonggi-do pp 2019-2023
- [9] Seneci C A, Shang J, Leibrandt K, Vitiello V, Patel N, Darzi A, Teare J and Yang G Z 2014 *IEEE/RSJ International Conference on Intelligent Robots and Systems (IROS)* IEEE Chicago pp 1314-21
- [10] Maeda S, Abe K, Yamamoto K, Tohyama O and Ito H 1996 *Micro Electro Mechanical Systems, 1996, MEMS '96, Proceedings. An Investigation of Micro Structures, Sensors, Actuators, Machines and Systems. IEEE, The Ninth Annual International Workshop on* IEEE pp 290-5
- [11] De Sars V, Haliyo S and Szewczyk J 2010 A practical approach to the design and control of active endoscopes *Mechatronics* **20(2)** 251-64
- [12] Perk O Y, Şeşen M, Gozuacik D and Koşar A 2012 Kidney stone erosion by micro scale hydrodynamic cavitation and consequent kidney stone treatment *Annals of biomedical engineering* **40(9)** 1895-902
- [13] Li Z, Feiling J, Ren H and Yu H 2015 A Novel Tele-Operated Flexible Robot Targeted for Minimally Invasive Robotic Surgery *Engineering* **1(1)** 73-78