

An X-band RFIC Active Phase Shifter

Mustafa Doğan^{1,2}

¹TÜBİTAK – BİLGEM – UEKAE
Gebze, Kocaeli, Turkey
mustafadogan@sabanciuniv.edu

İbrahim Tekin²

²Sabancı University, Electronics Engineering
Tuzla, İstanbul, Turkey
tekin@sabanciuniv.edu

Abstract— An active RFIC X-band phase shifter is implemented using IHP SiGe HBT 0.25 μm SGB25V technology with an improved vector sum method. The chip is formed by a three way Wilkinson power divider, three phase delays for 0-120-240 degrees, three similar RFIC LNAs and a final three way Wilkinson power combiner on the same chip and occupies an area of 4x1.8 mm². The circuit provides both phase and amplitude control without the need of any additional digital circuitry. Phase shifting is simply based on the weighted vector sum of three vectors which are separated by 120° from each other. All 0-360 degree phase can be scanned simply by this method with the addition of amplitude control. The RFIC LNA circuit is fabricated and measurement results show that LNA has a gain of 10 - 13 dB with in the band of 6-9 GHz and 2-3 dB NF within the same band. The simulation results show that the phase can be scanned from 0-360 degrees with average 7 degree resolution for a 2 dB amplifier gain change. The gain of the overall active phase shifter circuit is 12-13 dB with output gain flatness is 1 dB and the circuit consumes 15.36 mW power. The circuit combines the amplifier with phase shifter and can be used for X-band applications.

Keywords- RFIC active phase shifter, low noise amplifier, SiGe HBT, vector sum method.

I. INTRODUCTION

The recent advances in civil and military systems require advanced active phased array systems/TR modules. Advanced active phased array systems need efficient beam forming and beam scanning capabilities. Recent phased array systems provide these capabilities by increasing the number of radiating elements and by controlling the phase/amplitude of each of them by using phase shifters in front of each radiating element.

Several ideas have been proposed for phase shifting. Earlier studies on phase shifters focused on controlling only the phase of radiating element which only allows to beam scanning. Recent researches on phase shifters focus on controlling phase and amplitude of the signal, simultaneously. Polar modulation technique [1], [2] provides both amplitude and phase control with limited phase scanning. Paul and Gardner [3] proposed a quadrature phase shifter that is based on complex summation of two orthogonal variable vectors. The idea of S. J. Kim and N. H. Myung [4] provides variable phase shift and gain by adjusting the relative amplitudes of the vectors. All above mentioned techniques provides both amplitude and phase

control with a limited angular scan. In order to cover the whole angular sector, additional digital circuitry and other circuit elements such as switches will be required. The study presented by Koh and Rebeiz [5] provides phase/amplitude control with a whole angular scan capability by using I/Q filters and analog differential adders, which increases the circuit complexity.

In this paper, a new phase shifting scheme is presented which scans the whole phase spectrum without any needs of additional digital circuitry. Proposed design has the capability of both phase and amplitude control with a much simpler circuitry. It is formed by combination of power divider/combiner, phase delay lines and LNAs. LNAs play the crucial role in this topology. All the components are implemented on a single chip RFIC.

The rest of the paper is as follows: the main topology and the idea of controlling the phase/amplitude will be explained in the next section. Second, the design and manufacturing of X-band SiGe HBT based LNA will be presented with corresponding simulation and measurement results for gain and the noise figure (NF). Finally, simulation results of phase and amplitude variations for the overall active phase shifters which is a combination of power divider/combiner, phase delay lines and LNAs will be presented with a conclusion.

II. VECTOR SUM METHOD AND ACTIVE PHASE SHIFTER CIRCUIT

Proposed technique is based on the vector sum method; however it differs from previous vector sum method applications with the phase/amplitude shifting idea. In previous studies [6] and [7], two lines and a quadrature phase shifter has been used and this will only span the phase with in a limited quadrant. Fortunately, the scanning of whole 360 degree phase shift will be possible without additional circuitry with this new proposed technique.

In this new technique, the phase spectrum is divided into three equal region such as 0°-120°, 120° - 240° and 240° - 360°. The received signal is divided into three equal signals with three-way Wilkinson power divider. Then, the phase of each signal is shifted with fixed - phase delay lines (0°, 120° and 240°) and then amplified with corresponding LNAs. After amplification, the signals will be recombined with a three-way

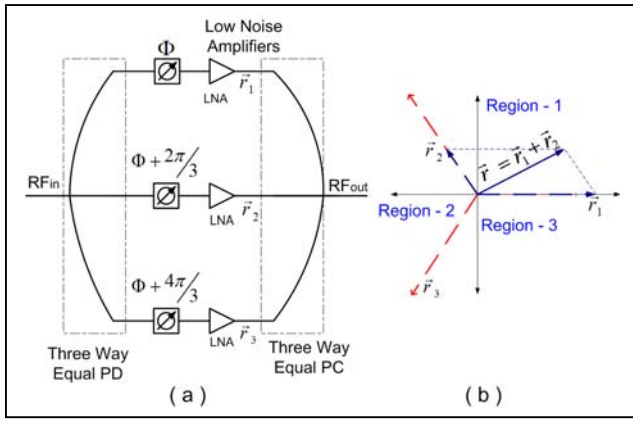

Figure 1. Main topology of proposed phase shifter

will operate with a desired gain and the remaining LNA will be turned off, or in our case, will be tuned to a different frequency by using varactors. For instance, in order to have an output signal with 30° phase, \vec{r}_1 and \vec{r}_2 should contribute to the output signal and hence LNAs on these lines will be on, and LNA on \vec{r}_3 line should be turned off or detuned as shown in Fig.1b. For phase between 0-120 degrees, LNAs on signal path 1-2 will be on, for phase between 120-240, LNAs on signal lines 2-3, and for phase between 240-360, LNAs on lines 1-2 will be turned on. Amplitude of the received signal is determined by the corresponding LNAs and vector sums of as shown in Fig.1. b.

Since the LNAs used in the phase shifter structure are fairly broadband, the proposed phase shifter will also be broadband and can be used within a band of 2 GHz in X-band. Using varactor in the LNA structure will shift the center frequency of the LNAs center in 2 GHz range in X-band region without significant variation in the gain and the noise figure.

III. LNA

LNAs are the key elements of the proposed active phase shifter. This section of the paper presents an X-band silicon-germanium (SiGe) single stage cascode tunable low-noise amplifier (LNA) as shown in Fig. 2. LNA is implemented by using IHP SiGe Heterojunction Bipolar Transistors (HBTs) 0.25- μm SGB25V technology. LNA is well matched from both input and output directions and optimized for the maximum possible gain and minimum possible noise figure. LC tank circuit specifies the operating frequency of the LNA. By connecting a variable capacitor (varactor) in parallel to the tank circuit, overall capacitance will enhance up to 200 – 250 fF, thus center frequency of the the LNA can be easily adjusted by varying the capacitance of the tank circuit. Cadence is used in collaboration with ADS during schematic and layout design and the simulation results depict that designed LNA dissipates 15.36 mW from an 2.4 V DC power supply and the maximum simulated gain (Fig. 3) around 20 dB in X-band while keeping NF below 2.5 dB (Fig. 4). Center frequency changes in 8.5 – 10.5 GHz band as the varactors voltage changes from 2.5Vdc to -2.5 Vdc. Reverse path isolation of the LNA is above 30 dB. The values of the circuit elements are tabulated in Table 1.

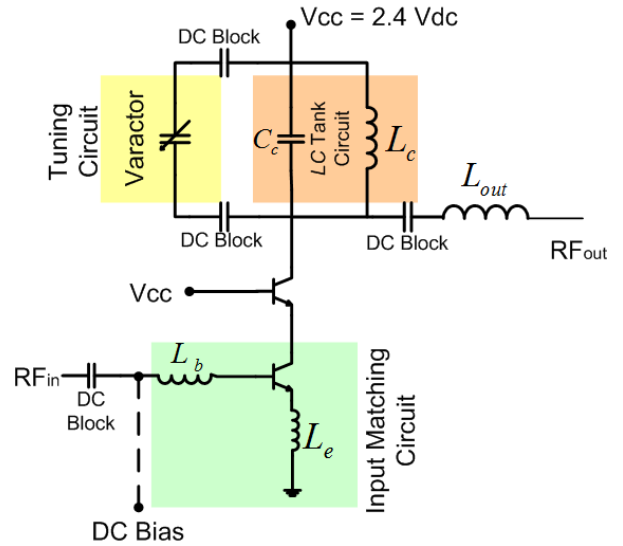

Figure 2. Circuit Diagram of Tunable LNA

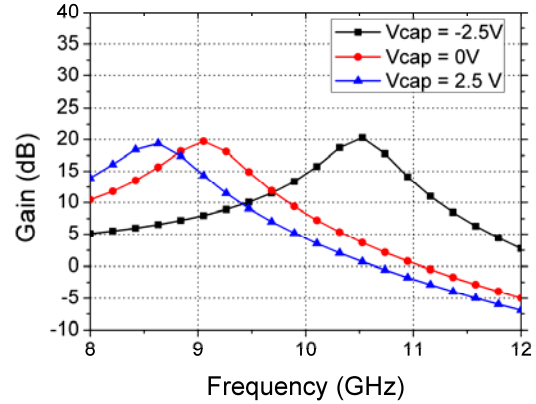

Figure 3. Simulated Gain Results

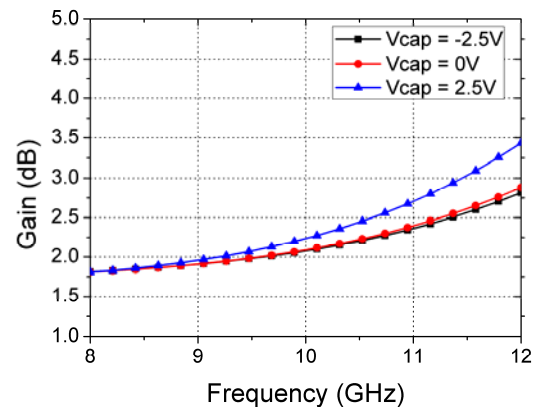

Figure 4. Simulated NF Results

TABLE I. CIRCUIT ELEMENT VALUES OF LNA

L_b	L_e	L_c	C_c	L_{out}
650 pH	150 pH	500 pH	250 fF	2.8 nH

Designed LNA is manufactured at IHP facilities by using the SiGe HBT 0.25- μ m SGB25V technology as shown in Fig. 5. Designed LNA occupies an area of 1.3 x 0.7mm². Several measurements are performed at Sabanci University, Faculty of Engineering and Natural Science RFIC laboratory with special measurement setup and probes. Gain of the LNA is measured by using network analyzer for different varactor voltages. As the varactor voltage increases from -2.5V to 2.5V the gain curve moves towards lower frequencies as shown in Fig. 3 and Fig. 6. Measured gain curves behave similarly to the simulated ones with a difference of center frequency. The frequency range shifts around 2 GHz due to the additional parasitic inductance and capacitance of the transmission lines and crossed layers. The capacitance of RF bond pads used in input and output is not known, RF deembedding is not applied to the results. The measured peak gain is 6-7 dB lower than simulated gain which will be due to the additional dielectric losses of the substrate and the measurement uncertainty. Then noise figure measurements are performed with a spectrum analyzer combined with noise source and the corresponding results are depicted in Fig. 7. NF is well below 3 dB in the operating frequency range. The profile of the NF curves fit to the simulated NF curves. The difference between NF becomes clear as the frequency increases. Lastly, 1dB compression point of the manufactured LNA is measured by simply sweeping the input power level from -60dBm to -5 dBm. Measured 1dB compression point of the manufacture LNA is -10dBm.

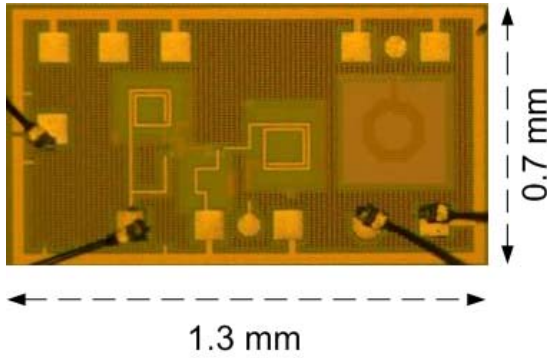

Figure 5. Photograph of manufactured LNA

IV. COMPLETE PHASE SHIFTER STRUCTURE

LNAs will be integrated with the power divider/combiner and phase delay lines on a single chip to complete the active phase shifter structure. The fully integrated layout of the proposed phase shifter is given in Fig. 8. First, on the left part of the circuit, three way Wilkinson equal power divider with proper input impedance matching is seen with the meander type microstrip transmission lines.

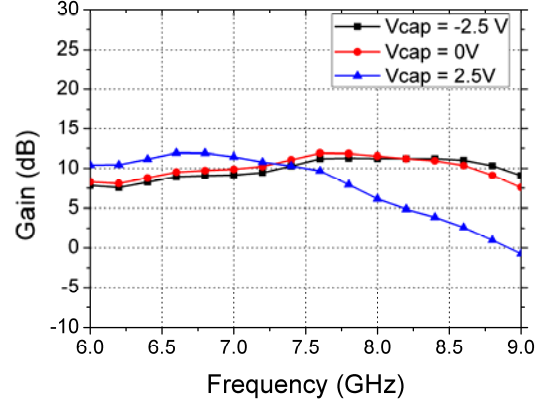

Figure 6. Measured Gain Results

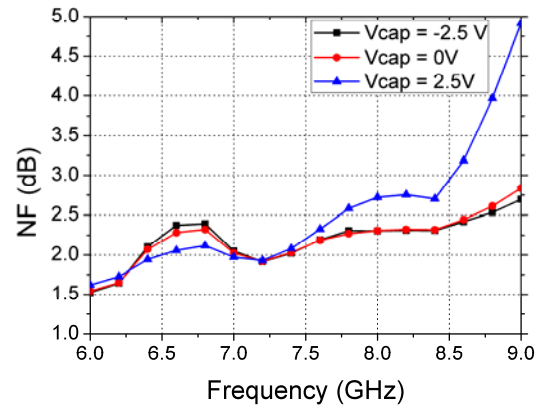

Figure 7. Measured NF Results

The design uses the advantage of multilayer metal structure of IHP SGB25V technology. TopMetal2 (TM2) which is the most top metal layer of among five metal layers is used as the signal line with 19.356 μ m width for 50 ohm impedance, 6.672 μ m for 86.6 ohm line impedance. Metal1 is used as the ground plane which is 11 μ m away from the TM2 layer. After the power divider section, phase delays are obtained for 0-120 240 degrees for simply adding different length microstrip lines with 50 ohms. Then each of the outputs are connected to three RFIC LNAs designed before. And the final stage is the power combiner, which is also same with the power divider on the left of the circuit. The circuit has an total area of 4x1.8mm².

Power divider/combiner, phase delay lines are simulated using ADS full EM software and the measurement results of LNA are combined in ADS to find phase/amplitude response of active phase shifter for different scenarios. The phase response is obtained by vector sum of two of three signal lines between 6-9 GHz. For instance, the phase response of r1+r2 is obtained by turning LNA3 off, changing the gain of LNA1 or LNA2 while the other LNA has fixed gain and vice versa. As shown in Fig. 9, 2 dB changes in the gain of one signal line will result an average of 7° phase shift at the output signal.

Also in Figure 10, the gain of the active phase shifter circuit is shown. 7 dB active phase shifter gain is obtained for the low noise amplifier gain of 13 dB. The maximum gain deviation at the center frequency is between 2-3 dB when the gain of only one LNA varies while other ones gain is at its maximum level. Designed active phase shifter will be delivered to IHP for production and more measurement result on phase/gain response will be shared at the conference.

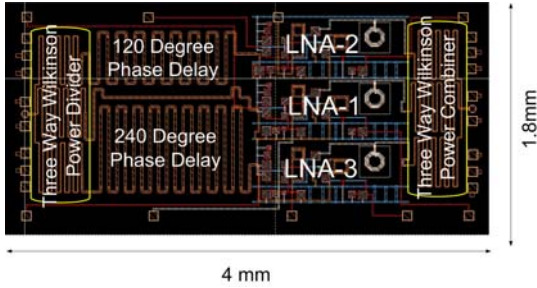

Figure 8. Fully Integrated Layout of Proposed Active Phase Shifter

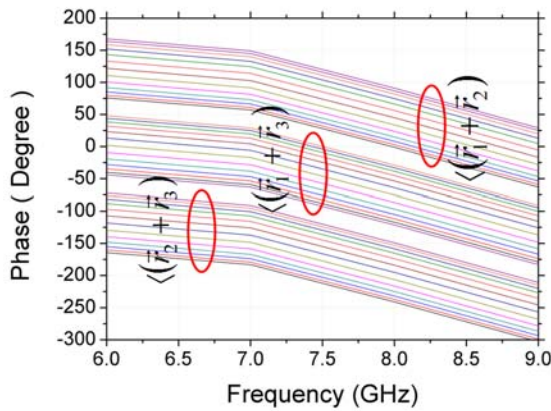

Figure 9. Insertion Phase Response of Active Phase Shifter

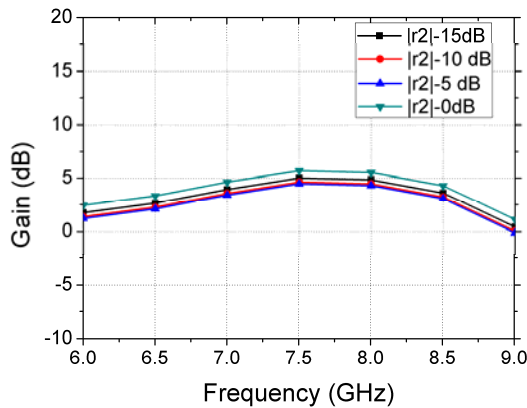

Figure 10. Gain Variation of Active Phase Shifter in Region-1

V. CONCLUSION

The design of X-band active phase shifter with an integrated tunable LNA on a single chip is proposed. Proposed phase shifter uses a modified vector sum method with a new phase/amplitude control technique. Simulations results of active phase shifter systems demonstrate 2dB variation in one of the LNAs gain will result an average of 7 degree phase shift at the output signal. The amplitude control capability is strictly limited by the low noise amplifiers gain, thus output signal amplitude will change up to 7 dB maximum.

Initial analysis and measurements demonstrate that designed active phase shifter will be a good candidate module in new low power active phased array systems with its high gain, good phase response and capability of amplitude control.

ACKNOWLEDGMENT

The authors would like to thank Mehmet Kaynak from IHP GmbH for being a part of this study by helping the authors at every stage of chip production.

REFERENCES

- [1] M. Chua, K.W. Martin, "1 GHz programmable analog phase shifter for adaptive antennas", Custom Integrated Circuits Conference, 1998., Proceedings of the IEEE 1998, 11-14 May 1998, pp.71 – 74.J. Clerk Maxwell, A Treatise on Electricity and Magnetism, 3rd ed., vol. 2. Oxford: Clarendon, 1892, pp.68–73.
- [2] P.S. Wu, H.Y. Chang, M.D. Tsai, T. W. Huang, H. Wang, "New miniature 15-20-GHz continuous-phase/amplitude control MMICs using 0.18- μm CMOS technology", Microwave Theory and Techniques, IEEE Transactions on Volume 54, Issue 1, Jan. 2006, pp. 10 – 19.
- [3] D. K. Paul, P. Gardner, " Microwave Quadrature Active Phase Shifter Using MESFETS," Microwave and Optical Technology Letters, Vol. 15, No. 6, 1997
- [4] S. J. Kim, N. H. Myung, "A New Active Phase Shifter Using a Vector Sum Method," IEEE Microwave and Guided Wave Letters, Vol. 10, No. 6, 2000.
- [5] K-J. Koh, G.M. Rebeiz, "0.13- μm CMOS Phase Shifters for X-, Ku-, and K-Band Phased Arrays", IEEE Journal of Solid-State Circuits, Vol. 42, No. 11, November 2007
- [6] S. A. Mitilneos, G. K. Mitropoulos, C. N. Capsalis, "A New Active Phase RF Phase Shifter Using Variable Gain, Drain Voltage Controlled PHEMTs: A 2.4 GHz ISM Implementation", IEEE Microwave and Wireless Components Letters, Vol. 15, No. 7, July 2005
- [7] T. M. Hancock, G. M. Rebeiz, "A 12-GHz SiGe Phase Shifter with Integrated LNA", IEEE Transactions on Microwave Theory and Techniques, Vol. 53, No. 3, March 2005