

ENERGYREPORT

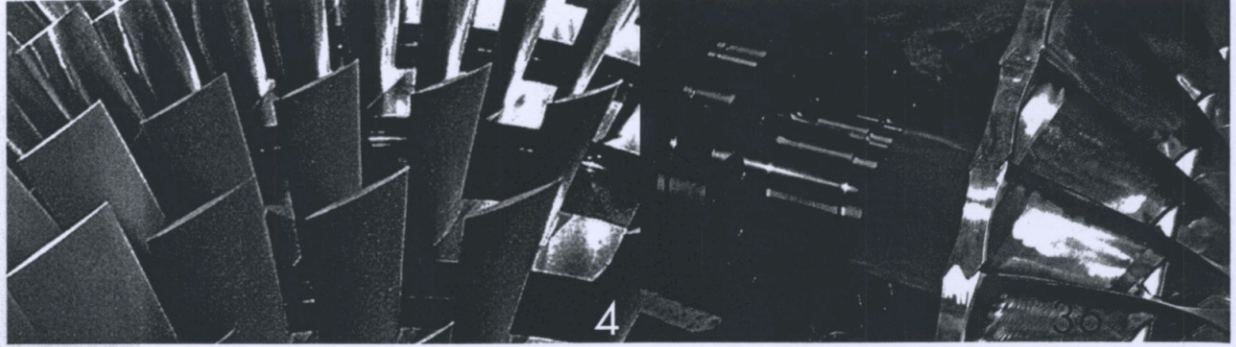
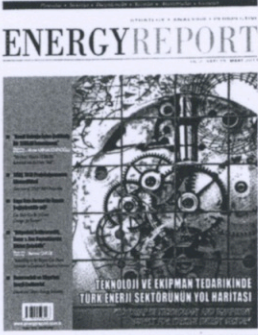

THE ENERGY REPORT
Mart/March 2011, Yıl 2 / Sayı 15

İmtiyaz Sahibi
YAYIN ATÖLYESİ
Yayınçılık Reklam Bilişim Hizmetleri Ltd. Şti. adına
Mete BELOVACIKLI

Sorumlu Yazı İşleri Müdürü
Fatma Gülçin KABASAKALLI
fkabasakalli@energyreport.com.tr

Yayın Kurulu
Mete BELOVACIKLI
Erdal SAÇLAM
F. Gülçin KABASAKALLI
İrem DOĞRUÖZ

Görsel Yönetmen
Turgay GÜVEN

Reklam-Abone Koordinatörü
Melike KÜPELİ
mkupeli@energyreport.com.tr
abone@energyreport.com.tr

Yayın Türü
Yaygın Süreli - Aylık
ISSN: 1309-5269

Baskı
Yalçın Matbaa / Ambalaj Sanayii
İvedik Organize Sanayi Bölgesi 1518. Sok.
Matsit İş Merkezi 2/14-15
Yenimahalle / Ankara
Tel: 0.312 435 0 435 - 395 2 116
Faks: 0.312 395 23 69
info@yalcinmatbaacilik.com.tr

İLETİŞİM BİLGİLERİ

Uğur Mumcu'nun Sokağı 61/5
G.O.P / ANKARA

Tel : 0.312 446 64 32 - 33
Faks: 0.312 446 64 38
info@energyreport.com.tr

5

TEKNOLOJİ VE EKİPMAN TEDARİKİNDE TÜRK ENERJİ SEKTÖRÜNÜN İKİLEMLERİ TURKISH ENERGY SECTOR'S DILEMMAS IN THE TECHNOLOGY AND EQUIPMENT SUPPLY

by Fatma Gülçin KABASAKALLI



16

"Kendi Kabuğu İçine Çekilmiş Bir TEMSAN İstemiyoruz"
"We Don't Want a TEMSAN Retreated into Its Own Shell"

INTERVIEW: Ahmet KARAMUSTAFAOĞLU

26

Elektrik Sektöründe Birincil Yerli Kaynak ve Teknoloji Kullanımının Önemi
Importance of Using Domestic Primary Sources and Technology in Power Sector

by Ahmet ELTEKİN

32

TEİAŞ 2019 Kapasite Projeksiyonunun Gösterdikleri
Overview of TEİAŞ 2019 Capacity Projection by Prof.Dr. Osman SEVAIOĞLU



36

TÜRKİYE'DE RÜZGAR
TÜRBİNİ ÜRETİMİ ALTYAPISI
WIND TURBINE MANUFACTURING
INFRASTRUCTURE IN TURKEY

by Doç.Dr. Mahmut F. AKŞİT

45

Rüzgar Enerjisinde Ekipman Üretimi
Equipment Production in Wind Energy by Ali ÇOLAK

Wind Turbine Manufacturing Infrastructure in Turkey

by Assoc. Prof. Mahmut F. AKŞİT / Sabancı University, Executive Board member of EÜAŞ

Although wind energy has been harvested by windmills for many ages, the real push for the development of modern wind turbines came in late 1970s. Driven by the oil crises, governments of many developed countries initiated massive efforts to develop alternative energy options. The Danish government started with two R&D projects: the Nibe A and Nibe B. Both turbines were 3-bladed 630kW upwind designs based on the so called Gedser turbine. About 3 million USD was invested in each project [1]. Germany spent over 100 million DM to develop its first 2 MW prototype. Starting from almost none in early 1980s, the installed wind power capacity has reached 159.2 gigawatts (GW) globally by the end of 2009 [2].

Development of Turkish wind energy market

A study by the Turkish Ministry of Agriculture showed that there were 41 windmills for generating electricity in 1961. These were mostly used for small power needs such as early radio sets in the Anatolian countryside. A later survey in 1979 revealed 23 electricity producing turbines with capacities lower than 1 kW [3,4]. While the use of wind turbines for general power utilization dates back to 1986 with a 55 kW capacity system at a hotel in Çeşme-İzmir, it took another

decade for wind farms to appear in Turkey. The first wind farm with three 500 kW turbines went online near Alaçatı-İzmir in February 1998. However, detailed wind maps were needed for the development of wind resources in Turkey. The first national wind energy potential map has been published in 1984 followed by a second version in 2002. However, these maps were very rough. They did not have the details and resolution needed by the wind market.

The Electricity Market Regulatory Authority (EPDK) started accepting wind power production licenses on November 1st 2007. License applications reached a total of 78 GW wind capacity. So far, the Electricity Market Regulatory Authority has issued wind power generation licenses for a total of 3910 MW. As of today, the installed wind power capacity of Turkey is 1329 MW [5]. The scale of the license applications also reflects the potential growth for wind

energy market in Turkey. The Electrical Power Resources Survey and Development Administration (EIEI) plans for a total of 20 GW wind energy connecting to Turkish power grid within 10 years. In line with the global trend which indicates doubling of installed wind capacity every 3 years, it will be realistic to estimate Turkish wind market to reach 40 GW size before 2030. Table 1 provides an overview for the growth of Turkish wind market. With current market value of 1 million Euro cost of wind turbine per MWs, the Turkey is expected to spend 55 billion USD next 20 years for the turbines alone. Currently, almost all industrial scale wind turbines are imported. Funneling such large amounts of resources abroad would not be economically viable. Therefore, domestic productions of wind technology and turbine systems are necessary.

↳ continued on page 40

Table 1. Growth of Turkish wind market.

	Wind Capacity	Turbine Cost
Currently installed wind capacity	1.33 GW	1.9 billion USD
Total licenses issued	3.91 GW	5.5 billion USD
EIEI* Planned capacity for 10 years	20 GW	28 billion USD
Expected wind capacity for 20 years	40 GW	55 billion USD

(*EIEI stands for the Electrical Power Resources Survey and Development Administration)

Current wind turbine manufacturing infrastructure

Wind turbines are complex electro-mechanical systems involving large forces and massive structures. A typical 2.5 MW turbine may reach 90 m in tower height, 100 m in blade span and over 100 tons in nacelle weight. Such large systems require extensive investment in infrastructure and manufacturing equipment. A wind turbine consists of the following main components: tower, nacelle, blades, and power modules. The nacelle houses the following subsystems: hub, main shaft and bearings, gear box, generator, inverter and transformers, cooling system, control and hydraulic systems. Figure 2 illustrates inner workings of a typical wind turbine [6].

Turbine manufacturing

Wind energy industry is its early stages in Turkey. Therefore, there is no large industrial scale (over 2 MW) turbine manufacturing in Turkey. However,

there are some manufacturers producing smaller scale machines. One company in Ankara is currently manufacturing its first 1.650 MW turbine under a foreign license. There are several companies trying to develop their own turbine technologies. These companies are many located near cities of Istanbul, Ankara and Izmir. Typically, these turbines are below 100 kW range. Among the turbine manufacturers which are focused on developing their own technology there are two which are known to have turbines over 100 kW. One of them is near Ankara which has ongoing efforts to develop 200 and 500 kW prototypes. The other company in Bursa which has already built its first 500 kW working prototype using a novel/patented blade construction with 3.2 lift coefficient [7]. This turbine is designed to achieve an extremely low cut-in speed of 1.5 m/s and to reach full load at 10 m/s wind speed. However, all three turbines have fixed wing attachments without blade pitch control. Government support is necessary to develop 2.5 MW large turbines or their major components.

Many small components are readily produced by many companies in Turkey. These components include bolts, nuts, cables, switches, circuit breakers, servo motors, high voltage transformers, hydraulics and brakes, cooling systems etc. The existing industrial infrastructure for large turbine components will be discussed one by one in the following section.

Manufacturing of blades

The composite blades for a 2.5 MW wind turbine can reach 40-50 m in length. There is extensive experience in Turkey in manufacturing of large composite structures such as composite boats and large water slides. However, adopting this experience to wind turbines requires large investments and development costs. A single mold for a typical 45 m blade may easily cost 2 million Euros. Therefore, companies prefer foreign partnership or manufacturing under license. There are two companies that are currently producing wind turbine blades under foreign license in Turkey. Both of these companies are located in Izmir. The first company is established in 2002 as a joint venture with Enercon GmbH. It has annual capacity of 1000 pieces of 22 m blades for E44/E48 turbines. These turbines are relatively small, producing power in 600-900 kW range. The other company produces blades under Fuji Heavy Industries license. This manufacturer is producing 39 m long blades for 2 MW turbines. Recently, a third company in Antalya has signed licensing agreement with a European turbine producer. The company has background and experience in large composite boats and waterslides manufacturing. They are planning to produce blades for 1.5 - 2 MW turbines.

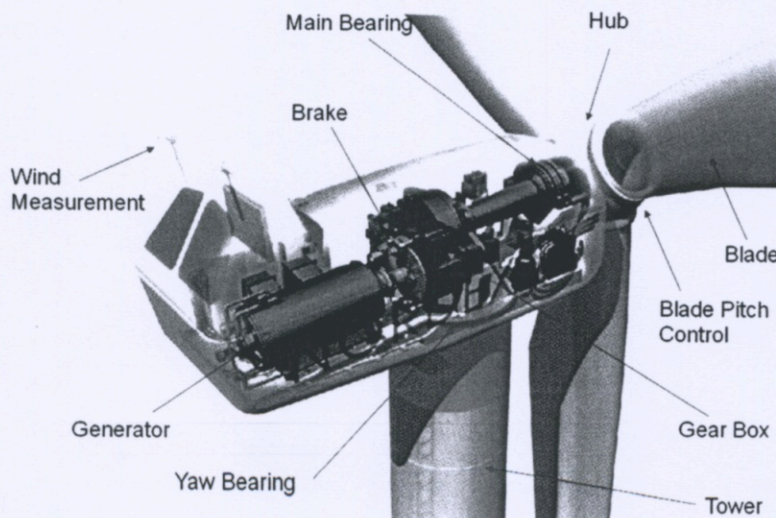

Figure 2. Components of a typical wind turbine as illustrated on NORDEX N80.

➤ continued on page 42

Manufacturing of towers

Turkey has very developed construction and steel industries. Therefore, there are many companies that are capable of manufacturing wind turbine towers. Some of these companies are already producing towers for foreign turbine manufacturers. The most well known is a company located in Gemlik. It is producing towers for Enercon GmbH and GE Wind Energy. The company has produced over 890 units totaling in excess of 700 MW capacity. Another company recently (2009) partnered with an Italian producer to manufacture towers up to 100 m size. The number of tower producing companies is expected to increase in the near future. Yet another company in Bursa is in the process of producing its first wind turbine tower.

Manufacturing of gear box

Gear box is one of the most challenging components in large wind turbines. As turbines get larger, rotor speeds get slower. This requires gear box ratios well over 100 under extreme torque values. Gear boxes in most large turbines have service periods of 3 years or less. Although there are dozens of gear manufacturers in Turkey, only a few can produce MW size gearboxes. All but one has no experience in producing gear boxes for wind turbines. Wind turbines require special planetary gears that are hard to produce. The only Turkish company that has produced gear boxes for wind turbines is located in Izmir. The company has produced 650 kW gear boxes for a wind farm in Turkey. Two other large gear manufacturers are located in Hadımköy and Beylikdüzü near Istanbul. The company with the capacity to produce the largest gears in Turkey is located in Tuzla near Istanbul. The company has produced custom gear boxes

up to 3 MW, and capable of producing gears 7 m in diameter.

Manufacturing of hubs and large castings

Turkey has the 6th place in Europe for casting capacity. There are over 1400 foundries; however, number of companies which can produce castings over 20 tons per piece is limited. One of the largest of such companies is located near Ankara. The company is capable of producing casting up to 30 tons. The company has produced hub castings for foreign wind turbine manufacturers. There are two other companies which can produce castings over 20 tons per piece. One of these companies is located in Bursa, and the other is in Izmir.

Manufacturing of generators

So far, no generators were produced over 500 kW in Turkey. There are several companies capable of producing 500 kW generators. One of them is near Balıkesir while a couple of them is located in Istanbul. A government owned company has equipment and infrastructure in its Diyarbakır plant capable of fabricating generators up to 32 MW and 13 m in winding diameter. However, this equipment has never been used, and company needs generator knowhow to produce large generators. Production of permanent magnet generators is almost nonexistent in Turkey.

Conclusion

There is extensive industrial infrastructure that will support production of large wind turbines in Turkey. However, due to lack of turbine technology and knowhow only a limited portion of this infrastructure is used towards wind turbine production. Most companies are

importing knowhow via partnerships and licensing. However, these turbines are typically smaller turbines (less than 2 MW) that are being phased out of production in the United States or Europe. Manufacturers in the developed countries are already producing turbines beyond 5 MW range. In order to get in global the wind turbine markets the required technology for larger wind turbines should be domestically developed. Due to massive scales of such turbines large investment costs are involved. Following Denmark and Germany examples in early 1980s, government support is needed through the learning curve and development phases. Recently Ministry of Energy has initiated the National Wind Energy Systems Project (MILRES) with funding from TUBITAK (The Scientific and Technological Research Council of Turkey). The project aims to develop turbine technologies up to 2.5 MWs as well as to coach potential component manufacturers to develop production capabilities for large turbines. ■

REFERENCES

- [1] Kristinsson, K. and Rao, R., "Learning to Grow: A Comparative Analysis of the Wind Turbine Industry in Denmark and India", DRUID-DIME Winter Conference, Aalborg, January 26-28, 2006.
- [2] "World Wind Energy Report 2009", World Wind Energy Association WWEA, March 2010.
- [3] Şahin, A.D., "A Review of Research and Development of Wind Energy in Turkey" CLEAN-Soil Air Water, 36, 9, 734-742, 2008.
- [4] M. Hanagasioglu, "Wind Energy in Turkey", Renew. Ener., 16, 822-827, 1999.
- [5] Data retrieved from the Electricity Market Regulatory Authority website, <http://www2.epdk.org.tr/lisans/elektrik/ye/yek.html>, March 2011.
- [6] Retrieved in March 2011 from <http://www.nordex-online.com/en/news-press/press-pictures.html>
- [7] Retrieved in March 2011 from <http://www.bostas.com.tr/>